

Light-Up Magnetic Tiles

Light-Up Magnetic Tiles are unique, personalized LED-lit scenes. They can be made out of a variety of materials and are intended for beginners to design and assemble by hand. Magnetic strips are used to hold the tiles to a metallic whiteboard and facilitate the electrical connections. In addition to being a mounting surface, the whiteboard also provides the 3V DC power to the tiles by means of a set of copper tape "rails". The tiles are illuminated when placed correctly on the board. Tiles are easily removed, and can be powered by a 3V coin cell battery to be displayed individually.

The base of each tile is a 5" x 5" square of lightweight material such as chipboard or corrugated plastic. On the back are 2 magnetic strips, spaced 3" apart like the power rails on the whiteboard. Several LEDs are embedded into the scene, either readily visible or such that they shine through thin material. The LEDs are connected in a parallel circuit using copper tape, then soldered to the copper tape. The positive and negative conductors from the circuit fold over to the back of the tile and over the magnetic strips, ready for contact with the power rails. The magnets hold the tile to the board and help make a secure electrical connection



Skills and Concepts:

- Circuit principles - insulators and conductors, series and parallel circuits, component selection based on voltage and current
- Tools and materials for electronic wiring
- Measurement and hand fabrication
- Soldering
- Troubleshooting

Material and specifications:

Materials for Mounting Board:

- 24" x 36" magnetic whiteboard
- 3V DC power source
 - Option 1: 2 batteries in a pack, size AA, or C or D
 - Option 2: 3V DC power supply, that can provide 2000mA current
- Copper tape with conductive adhesive, 1/4" wide
- Extra wire and wire-nuts (or solder, etc) to connect power to copper tape

Materials for Tiles:

- Lightweight material that does not tend to warp, such as chipboard, foam-core, or corrugated plastic
- Magnetic tape or strips, 1/2" wide with adhesive backing
- Craft materials such as origami paper, tissue paper, pipe cleaners, markers, scissors
- Hot glue guns and glue sticks- low temperature
- Copper tape with conductive adhesive, 1/4" wide, as used for mounting board
- LED assortment - choose LEDs with colored plastic so they can be identified easily

Instructions:

1. Create a powered mounting board as specified on the drawing (in Appendix)
2. Create blank tiles with magnetic strips.
 - a. Cut the blanks to be approximately 5" x 5"
 - b. Add magnetic strips, approximately 2" long, on the back of the tiles as shown below.
 - c. Mark the (+) and (-) sides. Facing you: (+) on right, (-) on left.

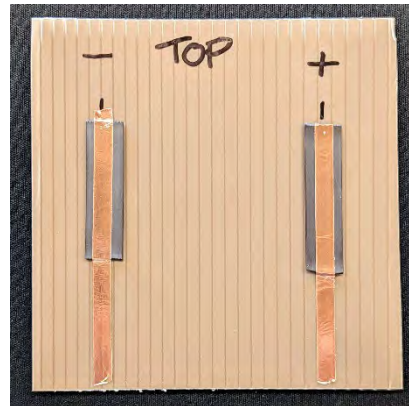
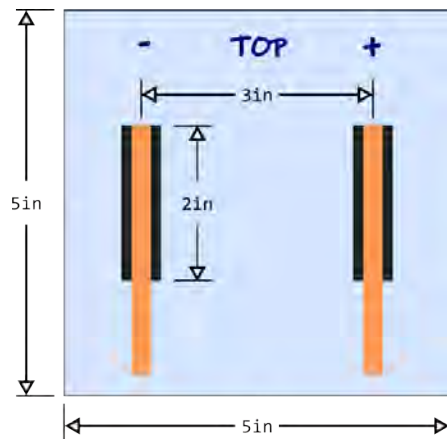

3. Create the scene:
 - a. Design and sketch out the scene on separate paper
 - b. Choose LEDs that require a similar voltage to turn on (usually specified on the package). LEDs come in two "families": 2V and the 3V. Red-yellow family LEDs will turn on with 2V, whereas blue-green-white family LEDs require 3V to turn on. If LEDs from the 2 families are mixed, for example Red and Green are wired in parallel, only the low voltage LEDs will turn on. (This can be fixed by using a small resistor in series with the low voltage LED, but it's easier just not to mix).



- c. Create the scene using craft materials
- d. Use a pushpin to poke two holes for the leads of each LED. Push each LED lead through the tile, paying close attention to which lead is POSITIVE (the longer one) and which lead is NEGATIVE (the shorter one.) It helps to insert all of the LEDs in the same direction – positive to the left or top, etc.
- e. Optionally, create the circuit on the front of the tile. Secure the LEDs using hot glue, being careful to not glue the leads of the LEDs.

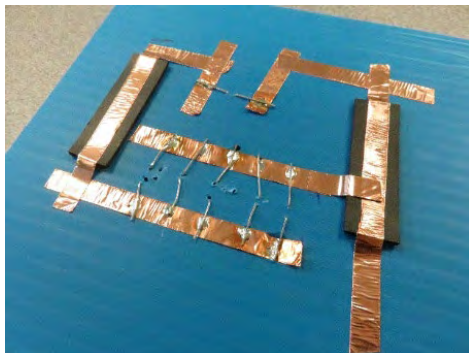

Circuit on back of tile

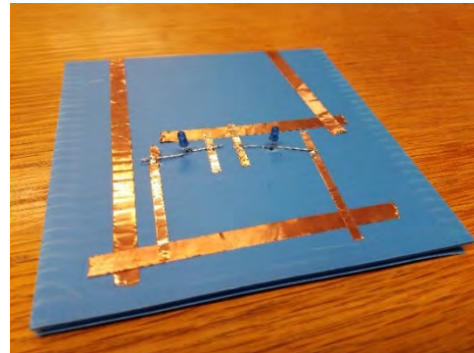

Circuit on front of tile

4. Create the circuit

- a. Identify the positive (+) and negative (-) ends of the LEDs and note it on the tile. (+) is the longer leg. Another way to identify the negative end is by a small flat on the plastic head of the LED.
- b. Layout the parallel circuit by drawing with pencil. Connect all the (+) ends together and run them to the (+) strip on the back of the tile. Connect all the (-) ends together and run them to the (-) strip on the back of the tile. The (+) and (-) can cross, but an electrical insulator will be needed.

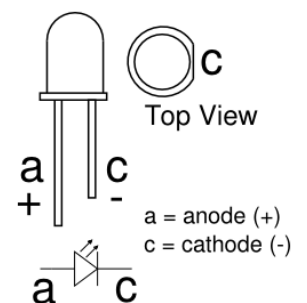

- c. Make the circuit using copper tape. Tape can be laid over other tape to continue or turn an electrical path. Run a fingernail or pencil point over the place where two pieces of tape meet to ensure a good electrical connection. If (+) and (-) need to cross, then cover the bottom conductor with a piece of masking or electrical tape to insulate it from the other conductor.
- d. Test the circuit. Use the powered board or an individual battery pack to test the circuit before it is soldered. You will need to hold the LED legs onto the copper tape, and may need to test each LED individually. Fix the circuit as needed.
- e. Solder the LEDs to the copper tape.



- f. Test the circuit and debug as needed. Check places where the copper tape overlaps. Add solder to these connections if needed. If the circuit is on the back, make sure nothing sticks up higher than the magnets – this can prevent a good connection to the board.
5. Complete the scene as desired.
 - a. The LEDs will shine through thinner papers (such as origami paper).
 6. Share all Light-Up Magnetic Tiles with the group!

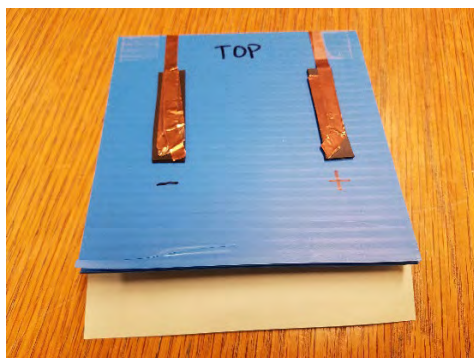

Back

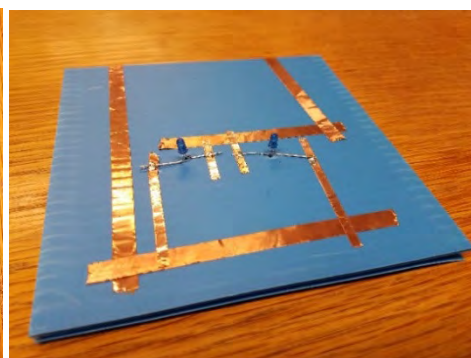

Front

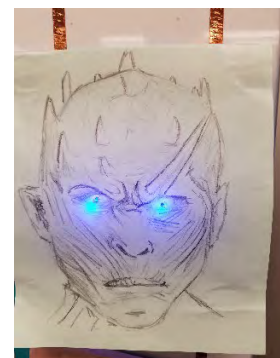

Front with scene

Sample Tiles

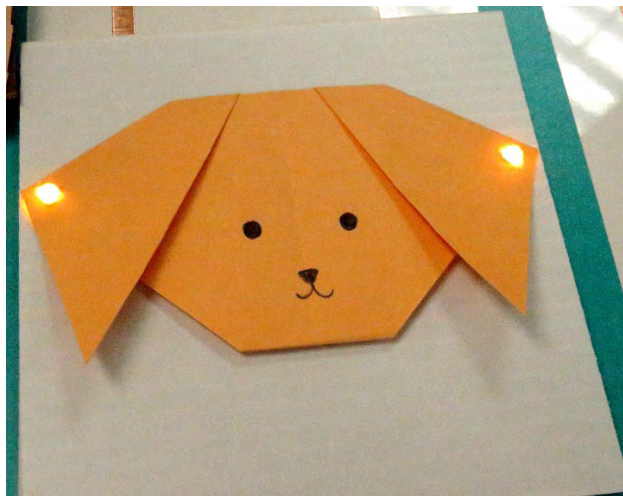
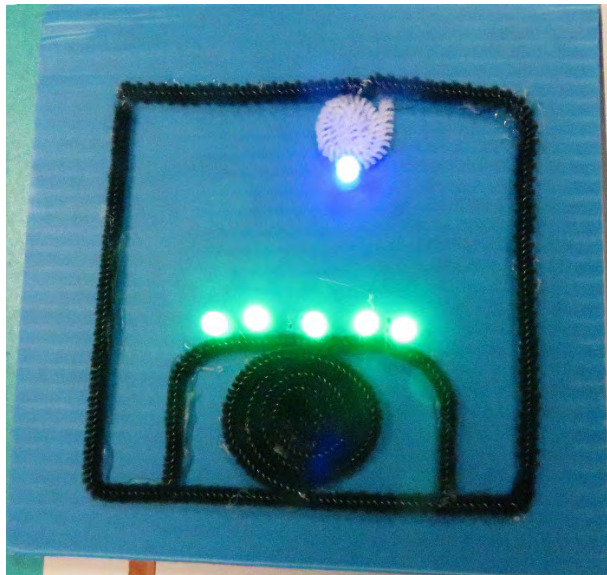
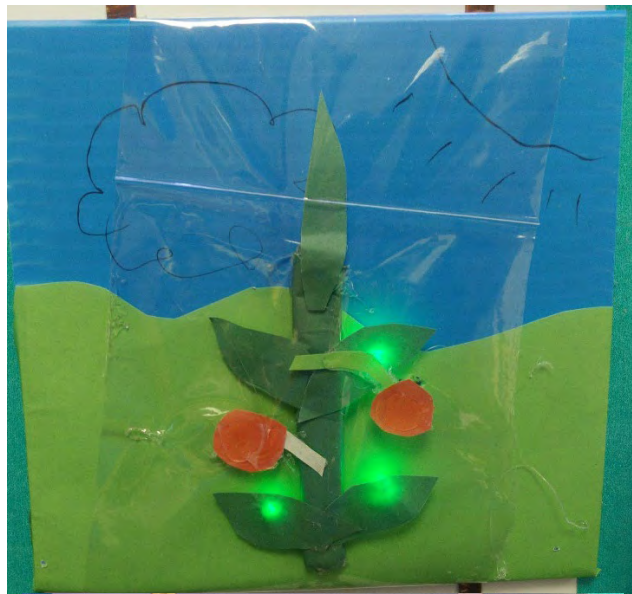

Magnetic Board Layout

